

ICC-2

INCLINED CONVEYOR

斜度運輸帶



CHARACTERISTICS

- * To lower down the working height of the production line.
- * Most suitable to receive the PCB from reflow oven or soldering machine to manual line.
- * Cooling fan(s) mounted along the conveyor line.
- * Parallelism of the conveyor can be kept within 0.5/1000mm.
- * Conveyor belt can stop automatically when conveyor is idle.
- * Use of low voltage electrical devices for safety operation.
- * Suitable for Auto or Manual Insertion and SMT lines.

特點

- * 可將流水線之工作高度降低.
- * 最常用於迴焊爐或錫爐至手插流水線.
- * 附加風扇降溫.
- * 運輸帶之平行度為 0.5/1000mm.
- * 等待時便可停止運輸.
- * 全部電器元件皆以 DC24V 或以下操作, 確保安全.
- * 適用於 AI, MI 及 SMT 流水線.

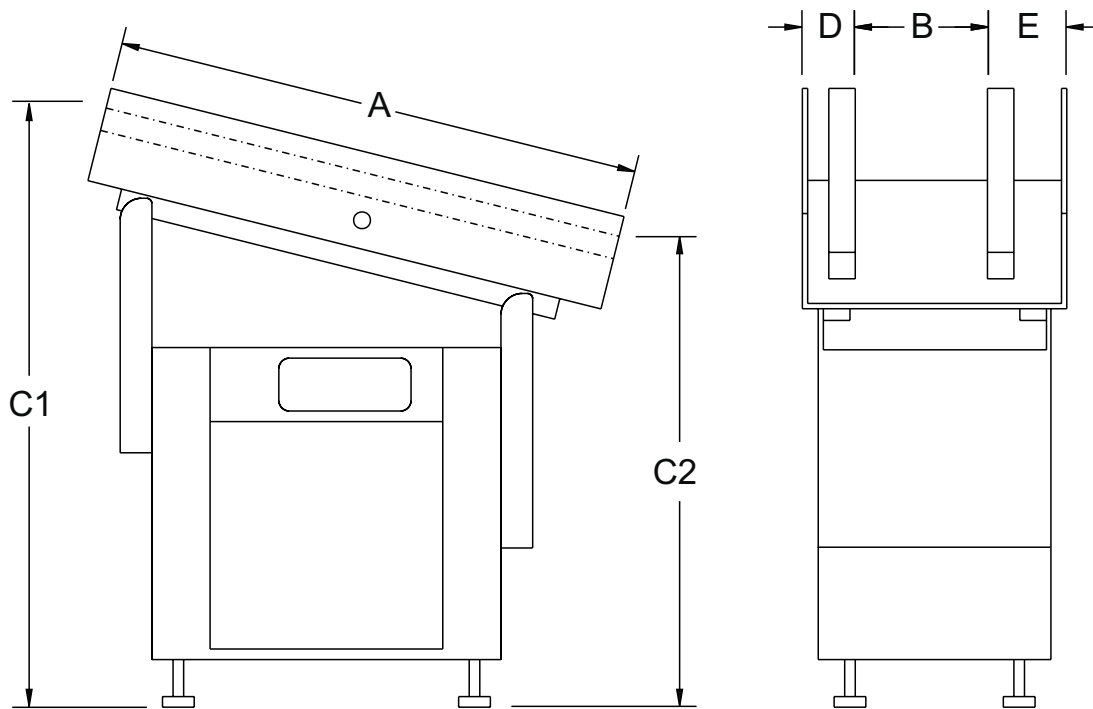

SPECIFICATION		規格	
A	mm	≥ 1000	
B Board width	基板寬度	mm	25~250/355
C1	mm	800~1050	
C2	mm	700~800	
Board transfer direction	送板方向		← / →
Adjustable transfer speed	可調速度	mm/sec	120~280 240~600
Edge clearance	承托基板寬度	mm	3.5/4.5
Power supply	電源	vac	110/220
No. of cooling fan(s)	風扇數量		≥ 1
No. of sensor	電眼數量		1
D	mm	75	
E	mm	105	



SMartop Technology Limited
創盛科技有限公司

Flat B, 9/F., Wing Yip Ind. Bldg., 21-27 Wing Yip St.,
Kwai Chung, N.T., Hong Kong.

香港辦事處：Tel : (852) 2790 4433/2790 4438

Fax : (852) 2790 5918

Email : sales@smartop.com.hk

中國辦事處：Tel : 86-769-556 1321/86-769-556 5921

Fax : 86-769-556 7183

Email : dg.sales@smartop.com.hk

